

# EBT-C AND EBT-CA BATTERY TORQUE TOOL

- The EBT-C and -CA models are based on the EBT series, but redefines what it means to be lightweight, compact and powerful.
- Accuracy up to  $\pm 3\%$ .
- Innovative cooling system prevents overheating and ensures continuous operation in demanding work conditions.
- Sensor-controlled gearbox and joint sensing technology guarantee precise and reliable tightening every time.
- "Safe to Start" button reduces the risk of accidental starts, increasing work safety.
- Powerful 18V/5.0 Ah battery provides long operating time on a single charge, making it especially suitable for demanding professional use.



Norbar battery torque wrenches are now available in an even more compact size. The EBT-C and -CA battery torque wrenches are based on Norbar's reliable and renowned EBT series but more than 20 % smaller than equivalent EBT torque wrench.

A new cooling system has been developed to fit into the smaller body without sacrificing on cooling power. These battery-powered wrenches are built to withstand even the toughest jobs and heaviest use. The gearbox is built using Norbar's decades of experience. With the EBT-C we can achieve an accuracy of  $\pm 5\%$  and with the EBT-CA we can reach up to an accuracy of  $\pm 3\%$  with the use of torque and angle function. This function allows us to get more accurate tightenings and it improves repeatability at the same time.

To improve work safety Norbar has added a "Safe to Start" button. With this button we can minimize accidental starts, greatly improving safety at work. The wrenches are powered by Norbar's 18V/5.0Ah batteries, allowing you to work uninterrupted for extended periods of time.

Your new EBT-C or EBT-CA battery torque wrench is delivered in a convenient carrying case, which includes the torque tool, two batteries, a charging dock, a reaction arm, a user manual, and a calibration certificate. Additionally, a wide range of versatile accessories is available to make work even more flexible in demanding conditions.



The EBT-CA series is equipped with an torque and an angle function. These functions allows us to create different tightening programs. By combining torque and angle functions we can achieve more accurate tightening results.

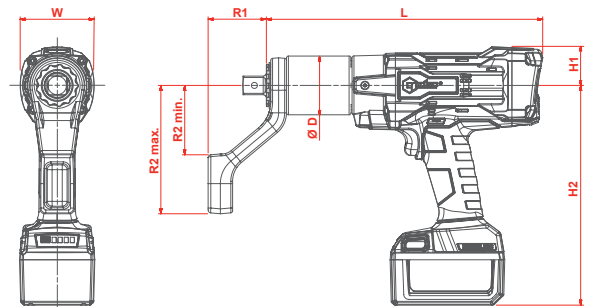
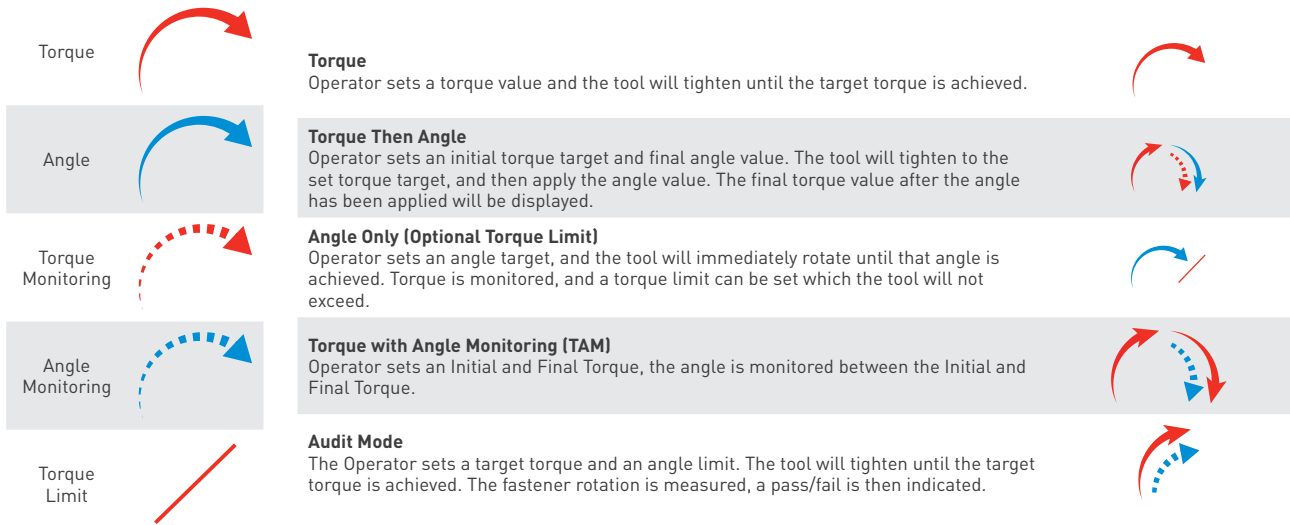

Model	Item	Drive	Operating range Nm	Calibrated range Nm	Dimensions mm							Free speed rpm	Weight kg*	Reaction arm kg	
					ØD	H1	H2	L	R1	R2 min.	R2 max.				W
EBT-C 750	181473	3/4"	75 - 750	150 - 750	60	39	224	282	60	71	131	76	12.5	3,1	0,8
EBT-C 1100	181477	3/4" & 1"	110 - 1 100	220 - 1 100	68	39	224	293	69	120	165	76	9.1	3,8	1,4
<b>USB</b>															
EBT-CA 750	181474	3/4"	75 - 750	150 - 750	60	39	224	282	60	71	131	76	12.5	3,1	0,8
EBT-CA 1100	181478	3/4" & 1"	110 - 1 100	220 - 1 100	68	39	224	293	69	120	165	76	9.1	3,8	1,4
<b>BLE</b>															
EBT-CA 750	181475	3/4"	75 - 750	150 - 750	60	39	224	282	60	71	131	76	12.5	3,1	0,8
EBT-CA 1100	181479	3/4" & 1"	110 - 1 100	220 - 1 100	68	39	224	293	69	120	165	76	9.1	3,8	1,4
<b>XBEE</b>															
EBT-CA 750	181476	3/4"	75 - 750	150 - 750	60	39	224	282	60	71	131	76	12.5	3,1	0,8
EBT-CA 1100	181480	3/4" & 1"	110 - 1 100	220 - 1 100	68	39	224	293	69	120	165	76	9.1	3,8	1,4

\*) Without battery and reaction arm

# REACTION ARMS



1

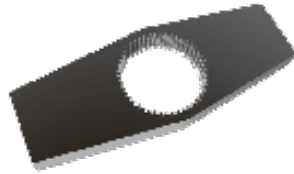

2



3



4



5



6



7



8



9



10



11



12



13



14



15

No.	Reaction arm	Compatible series
1	Splined Reaction	52 / 68 / 72 / 80 / 92 / 119
2	Double-Sided Reaction Plate	52 / 68 / 72 / 80 / 92 / 119
3	Straight Reaction Plate	52 / 68 / 72 / 80 / 92 / 119
4	Double-Sided Straight Reaction Plate	52 / 68 / 72 / 80 / 92 / 119
5	Long Straight Reaction Plate	52 / 68 / 72 / 80 / 92 / 119
6	Light-Weight Reaction	72
7	Sliding Spigot Reaction Plate	68
8	Sliding Reaction	52 / 68 / 72 / 80 / 92 / 119
9	Pegged Reaction Plate for rail	52 / 72
10	Reaction Adaptor	52 / 72
11	Straight Reaction With Peg	52 / 72
12	Short Reaction Foot	52 / 72
13	Straight Reaction	52 / 72
14	Sliding Reaction Spigot	52 / 72
15	Reaction Weld Ring	52 / 68 / 72 / 80 / 92 / 119