

NORBAR EBT BATTERY TORQUE TOOL

The Norbar EBT series sensor-controlled cordless wrenches feature brushless motors as well as built-in data collection and transmission capabilities. Years of dedicated development, combined with Norbar's high-quality gearbox, have resulted in a cordless wrench series that surpasses others in quality, speed, and accuracy.



- Accuracy better than $\pm 3\%$
- Next-generation brushless motor – maintenance-free
- Norbar's renowned and robust gearbox – over 10 years of product development
- Quick and easy gear replacement
- Powerful LED light for illuminating the work area
- Ergonomically designed handle and trigger
- Durable steel reaction arm included as standard
- 18 V/5.0 Ah battery ensures outstanding performance

The wireless Norbar EBT cordless torque tool is a reliable choice for all industrial and assembly tightening applications. The 18V/5.0 Ah battery and high-performance electric motor provide excellent working power without the risk of overheating, even in long-duration tasks. The tool is available in both single-speed and automatic two-speed versions.

With comprehensive usability-enhancing features, such as an OLED display, LED work light, "ease-of-use mode," and an optional safety trigger, the EBT torque tool ensures seamless and safe operation at all times. The EBT cordless tool package includes a work balancer as standard, along with a convenient carrying case for easy storage and transportation. Additionally, the wrench supports a wide range of accessories to enhance usability, including reaction arms for better handling in tight or difficult spaces.

The torque tool can be purchased as a standalone tool body or as a full package, which includes two batteries and a charging dock capable of simultaneously charging up to three batteries. Charging three empty batteries from zero to full takes approximately 45 minutes.

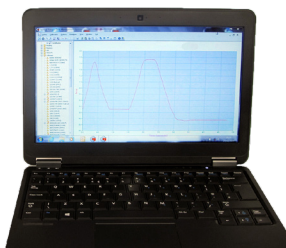

ToolSync software included as standard in the EBT wrench for data management and tool configuration

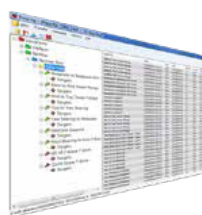

Real-time transmission of log data

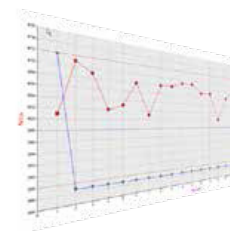

Ability to generate and store real-time graphics

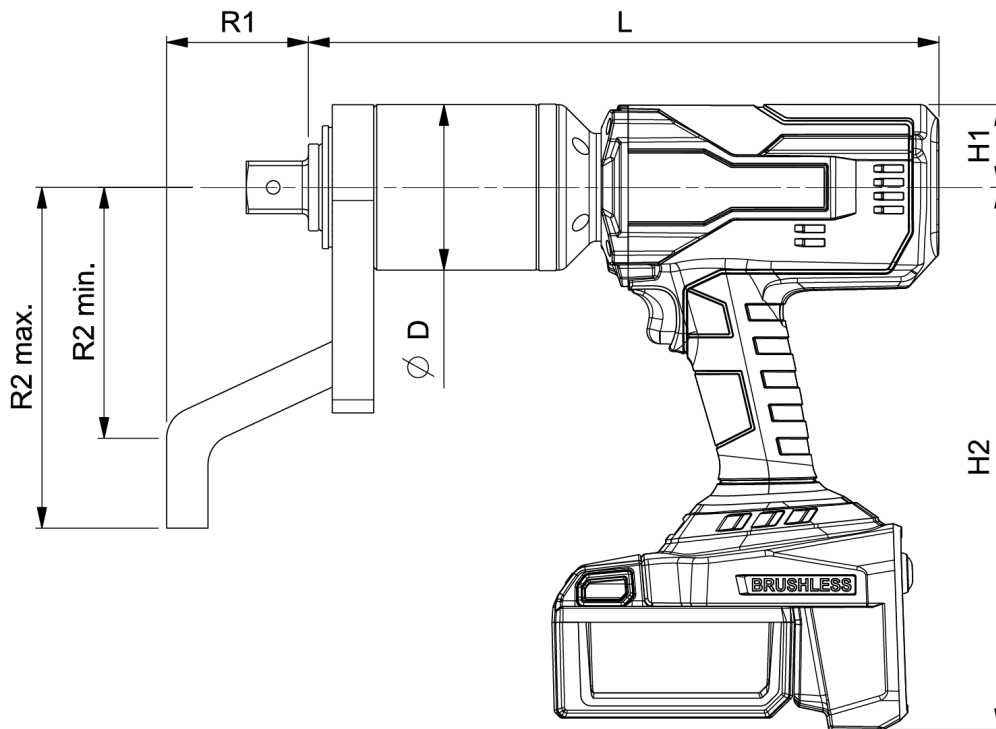

TECHNICAL SPECIFICATIONS

Model*	Item	Drive	Operating Range Nm	Calibrated Range Nm	Dimensions mm							Free Speed rpm	Weight kg**	Reaction Arm kg
					ØD	H1	H2	L	R1	R2 min.	R2 max.			
Single Speed														
EBT-52-800	181491	3/4"	100 - 800	160 - 800	52	40	262	271	59	68	131	11,2	3,7	0,8
EBT-72-1350	181493	3/4" & 1"	120 - 1 350	200 - 1 350	72	40	262	298	76	124	167	6,5	5,7	1,4
EBT-68-2000	181494	1"	200 - 2 000	400 - 2 000	68	40	262	294	75	133	165	4,2	4,9	1,1
EBT-80-2700	181495	1"	270 - 2 700	400 - 2 700	80	40	262	298	76	124	167	3,3	5,9	1,4
EBT-92-4000	181496	1"	400 - 4 000	800 - 4 000	92	40	262	352	70	125	175	2,3	7,9	2,5
EBT-119-7000	181497	1 1/2"	1 400 - 7 000	1 400 - 7 000	119	40	262	378	90	160	210	1,2	13,1	3,9
Auto Two Speed														
EBT-72-1350	181501	3/4" & 1"	338 - 1 350	338 - 1 350	72	40	262	317	76	124	167	32,0	5,9	1,4
EBT-80-2700	181503	1"	676 - 2 700	676 - 2 700	80	40	262	333	76	124	167	13,0	6,8	1,4
EBT-92-4000	181504	1"	1 000 - 4 000	1 000 - 4 000	92	40	262	387	70	125	175	9,5	8,3	2,5

*) All models can be equipped with a safety switch requiring two-handed operation.

***) Tool weight excludes both reaction and battery.



Reaction arm



Angle gear



Support handle



18 V/5,0 Ah battery



OLED screen